



# Teacher Resource Packet

Art Through Time  
Supplemental Materials  
Grades 3-5



# Table of Contents

## Planning Your Visit

Letter of Introduction	4
Curriculum Connections	5
Using this Packet	6
Planning Your Visit	7
Directions to Tudor Place	8
Name Tag Template	9

## Pre-Visit Activities

Pre-Visit Lesson Plans Overview and Answer Key	12
Democracy in Greece, Rome and the United States	14
Student Worksheet: Democracy in Greece, Rome and the United States	17
Student Worksheet: Classical and Neoclassical Architecture	19
The Love of Gold: Mathematical Application	21
Optional Student Worksheet: Surface Area and Volume	25
Student Worksheet: From Gold Nuggets to Gold Frames	27

## Post-Visit Activities

Post-Visit Lesson Plans	30
Art Description and Comparison	32
Creative Writing: Myths	34
Student Worksheet: Creative Writing: Myths	36
Ancient Greek and Roman Painting and Sculpture Game	38
Glossary	40

# Planning Your Visit

Dear Educator,

Thank you for your interest in Tudor Place's *Art Through Time* School Program. This program explores the connections between the world of Ancient Greeks and Romans and early nineteenth-century Americans who looked to them for inspiration. The program provides students with the opportunity to experience history by analyzing artifacts and making connections between them. The *Teacher Resource Packet* has been developed to enhance your class visit to Tudor Place.

The information and lessons in this packet should help you plan your classroom lessons in conjunction with your field trip at Tudor Place.

The Tudor Place Education Department recommends looking over the *Planning Your Visit* section and use the *Pre-Visit* lesson plans before your field trip to Tudor Place. The *Post-Visit* lesson plans will help reinforce concepts learned at Tudor Place.

This *Teacher Resource Packet* reflects the museum's mission to broaden public understanding of Washington D.C.'s unique history.

We look forward to your visit!

Sincerely,  
Education Staff  
Tudor Place

# Curriculum Connections

*Art Through Time* meets local and national educational standards. National standards are listed below.

## *Standards of the National Council for the Social Studies*

Students will:

- Explore and describe similarities and differences in the way groups, societies, and cultures address similar human needs and concerns
- Describe ways in which language, stories, folktales, music, and artistic creations serve as expressions of culture and influence behavior of people living in a particular culture
- Identify and use various sources for reconstructing the past, such as documents, letters, diaries, maps, textbooks, photos and others
- Describe how people create places that reflect ideas, personality, culture, and wants and needs as they design homes, playgrounds, classrooms and the like
- Explain the purpose of government

## *Standards for the English Language Arts*

Students will:

- Read a wide range of print and non-print texts to build an understanding of texts, of themselves, and of the cultures of the United States and the world
- Adjust their use of spoken, written and visual language to communicate effectively with a variety of audiences and for different purposes
- Use a variety of technological and information resources to gather and synthesize information and to create and communicate knowledge
- Develop an understanding of and respect for diversity in language use, patterns, and dialects across cultures, ethnic groups, geographic regions, and social roles

- Use spoken, written, and visual language to accomplish their own purposes

## *Standards for the Visual Arts*

Students will:

- Know and compare the characteristics of artworks in various eras and cultures
- Describe and place a variety of art objects in historical and cultural contexts
- Analyze, describe, and demonstrate how factors of time and place influence visual characteristics that give meaning and value to a work of art
- Compare multiple purposes for creating works of art
- Analyze contemporary and historic meanings in specific artworks through cultural and aesthetic inquiry
- Compare the characteristics of works in two or more art forms that share similar subject matter, historical periods, or cultural context

## *Standards for Mathematics*

Students will:

- Understand the effects of multiplying and dividing whole numbers
- Develop fluency with basic number combinations for multiplication and division
- Develop fluency in adding, subtracting, multiplying and dividing whole numbers
- Identify, compare, and analyze attributes of two- and three-dimensional shapes and develop vocabulary to describe the attributes

# Using this Packet

Use the following icons to help guide you through the Teacher Resource Packet



## **Teacher Preparation**

Use these pages to prepare your lessons and plan the field trip.

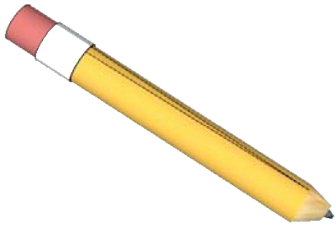

## **Student Preparation**

These sheets should be copied and distributed to students.



# Planning Your Visit Checklist

## Before Your Field Trip:

- Read the *Teacher Resource Packet*.
- Use the *Pre-Visit* lesson plans to introduce students to Tudor Place and prepare for the visit.
- Use the name tag template to make name tags for your students.

## The Day of Your Field Trip:

- Use the bathroom before leaving school. There are only two visitor restrooms at Tudor Place.
- Help students put on their name tags.
- Remind students of appropriate museum manners.
- Bring 2 chaperones, preferably classroom aides or other teachers.
- Remind chaperones that they are responsible for keeping the group together and well-behaved during the museum visit.

## After Your Field Trip:

- Complete the evaluation form and return it to Tudor Place.
- Use the Post-Visit lesson plans to reinforce concepts learned on your field trip.



# Directions to Tudor Place

## Location

1644 31<sup>st</sup> Street, NW, Washington, D.C., between Q and R Streets.  
Tudor Place is a 20-minute walk from the Dupont Circle or Foggy Bottom Metrorail stops. Metrobus stops are nearby. Ample street parking is available.

## From Northern Maryland

Take I-270 South towards Washington.  
I-270 South becomes Wisconsin Avenue, Rt. 355.  
Stay on Wisconsin Avenue for 6-7 miles (15-20 minutes) and go past the National Cathedral.  
Make a left turn onto Q Street. Go two blocks.  
Make a left onto 31<sup>st</sup> Street. Tudor Place is located at 1644 31<sup>st</sup> Street, NW.  
Look for the large gate and tour entrance on the left.

## From Philadelphia or Baltimore

Take I-95 South. As you approach the Washington Beltway (I-495) follow directions to I-495 towards Silver Spring or Rockville only.  
Continue on I-495. After the Connecticut Avenue exit, stay in the right lane.  
Exit I-495 at Wisconsin Avenue, Rt. 355. Follow the signs to Wisconsin Avenue South.  
Continue on Wisconsin Avenue for 6-7 miles (15-20 minutes) and go past the National Cathedral.  
Make a left turn onto Q Street. Go two blocks.  
Make a left onto 31<sup>st</sup> Street. Tudor Place is located at 1644 31<sup>st</sup> Street, NW.  
Look for the large gate and tour entrance on the left.

## From Northern Virginia

Cross Key Bridge (stay in the right lane).  
Turn right onto M Street and continue through three traffic lights, crossing Wisconsin Avenue.  
At the third light, turn left onto 31<sup>st</sup> Street and continue for 6 blocks.  
Tudor Place is located at 1644 31<sup>st</sup> Street, NW.  
Look for the large gate and tour entrance on the left.



# Map to Tudor Place

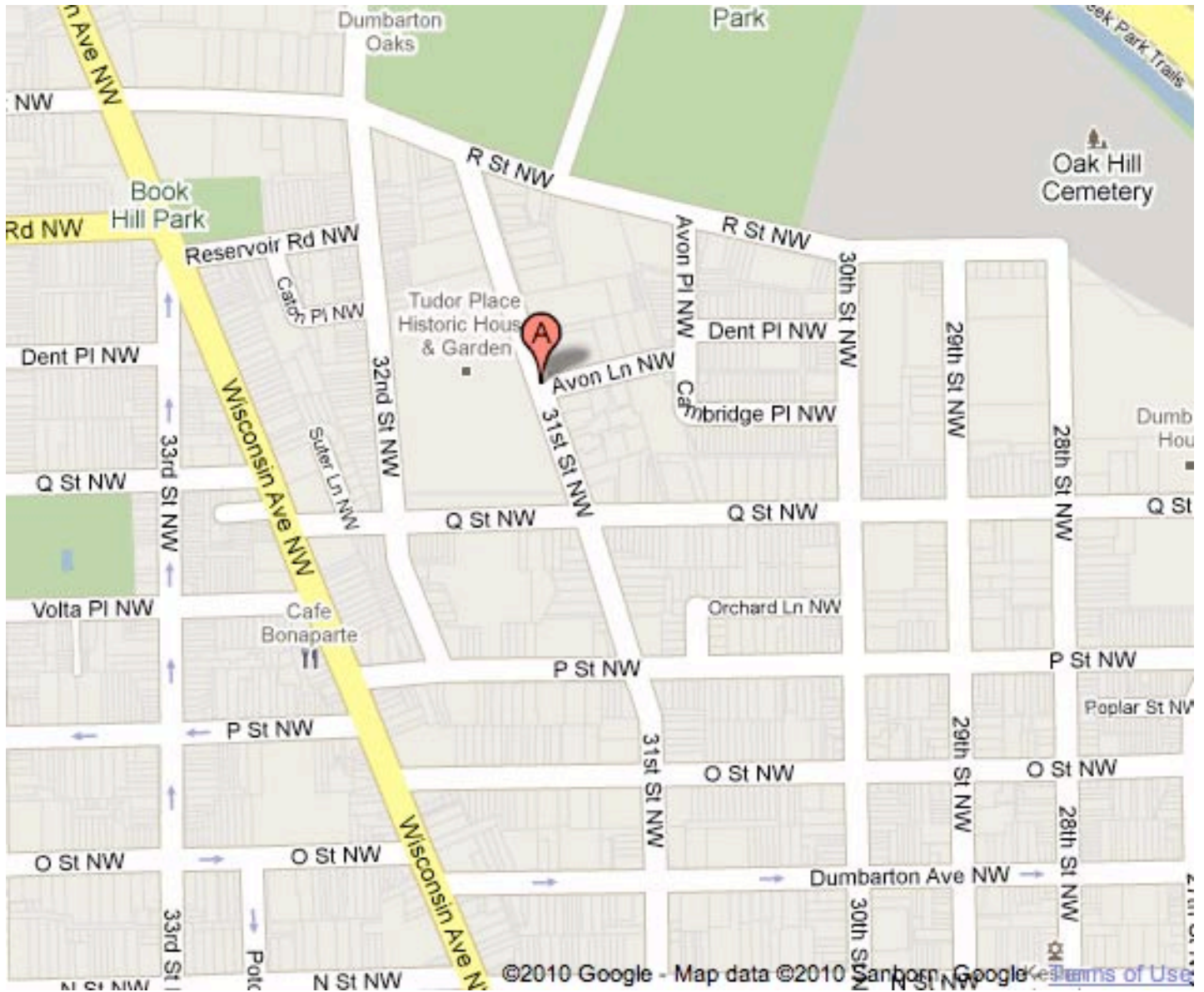

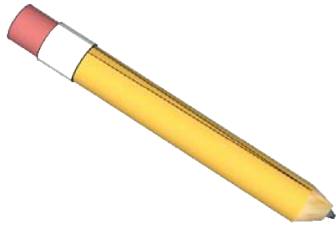

# Name Tags

**Directions:** Write your first name on the image of Tudor Place. Cut out your name tag and tape or pin it to your shirt with the help of your teacher.





## Pre-Visit Lesson Plan

Listed below are lesson plans for you to use with your class before visiting Tudor Place. All activities correspond to local and national curriculum standards.

### Activity 1: Ancient Greek and Roman Influences on US Government

*Objective:* After completing this worksheet, students will be able to:

- describe the differences between a direct democracy and a representative democracy
- identify how the governments of ancient Athens and ancient Rome influenced the United States government

*Answer Key:*

1. Direct democracy
2. Representative democracy
3. All Citizens can vote on issues
4. Citizens elect representatives to make laws in Congress (and at the state and local levels), and other acceptable answers
5. Accept all reasonable answers.
6. Accept all reasonable answers.

### Activity 2: Classical and Neoclassical Architecture

*Objective:* After completing this worksheet, students will be able to:

- identify three aspects of ancient architecture: the dome, the column and the arch
- identify these architectural elements on a specific structure
- identify which elements were used in ancient Greek and ancient Roman structures

*Answer Key:*

1. Drawing of a column (tall cylindrical object, or simply two parallel vertical lines with straight or curved lines at top and bottom)
2. Drawing of an arch (any width, can have horizontal line at bottom or not)
3. Drawing of a dome—accept all reasonable approximations
4. Dome
5. Column
6. Arch
7. Ancient Rome and Early 19<sup>th</sup>-century United States
8. Ancient Greece, Ancient Rome and Early 19<sup>th</sup>-century United States

### Optional Math Activity: Surface Area and Volume

*Objective:* After completing this worksheet, students will be able to:

- calculate volume, area and surface area for rectangular prisms
- apply arithmetic to real life questions
- connect a mathematic lesson with the process of gilding

*Answer key:*

Volume

1.  $8 \text{ in}^3$
2.  $12 \text{ in}^3$
3.  $160 \text{ in}^3$
4.  $120 \text{ in}^3$

Area

5.  $40 \text{ ft}^2$
6.  $120 \text{ ft}^2$

Surface Area

7.  $28 \text{ in}^2$
8.  $32 \text{ in}^2$
9.  $148 \text{ in}^2$

10. Word Problem

- a.  $40 \text{ in}^2$
- b.  $72 \text{ in}^2$
- c.  $112 \text{ in}^2$
- d. Yes

Bonus: Raul will need  $240 \text{ in}^2$  total (or, an additional  $120 \text{ in}^2$  to what he already has).

### Activity 3: The Love of Gold

*Objective:* After completing this worksheet, students will be able to:

- understand the process and organize the steps for how gold is changed into gold sheet for gilding.

*Answer key:*

- |  |  |
|--|--|
| 6. Applying glue to frame.                   | 2. Hammering gold sheet.                 |
| 3. Cutting gold sheet to make a packet.      | 7. Using gilder's tip to lift gold leaf. |
| 4. Hammering packet of gold to make thinner. | 1. Flattening gold nugget.               |
| 5. Cutting flattened sheet to flatten again. | 8. Burnishing gold leaf to make smooth.  |



## Activity 1: Democracy in Greece, Rome and the United States

### Teacher Information and Lesson Plan

**Rationale:** This lesson and related activity are intended to provide students with an understanding of three different forms of government used in Ancient Greece and Ancient Rome. Students will then be able to compare these governments to the monarchy experienced by the first United States colonists and the government that the founding fathers in turn created. Students should learn that the founding fathers looked to Ancient Greece and Rome when deciding how to structure the new government.

#### Materials:

- Map of the Mediterranean
- Paper and writing utensils for each group
- Overhead projector, chalk board, or white board
- Corresponding worksheet
- Optional: Corresponding PowerPoint Presentation (Number of related slides noted in parenthesis)

1. Explain that Ancient Greek and Ancient Roman culture has greatly influenced countries and cultures that have followed after it. Art and architecture still shows the influence from these cultures. In the 18<sup>th</sup> century (the 1700s) many people from like England traveled to ancient Greece and Rome and some discovered archeological sites. By digging these sites, people discovered buried artworks and archeological artifacts that taught them about what life was like in ancient Greece and Rome. In addition to buildings and decoration, Greek and Roman culture heavily influenced the United States government when the founding fathers were creating this new country in the late 18<sup>th</sup> century. (4 slides)
2. Review the basic information about the founding of the United States—that before it was the United States it was a colony of Great Britain; Great Britain had a king and some colonists rebelled against the rules the king was making the colonists follow; the colonies declared independence in 1776, fought a war, won the war, then had to establish a new system of government. (1 slide)
3. Introduce the idea of *government*. Explain that a government is a group of people who set laws for the whole group (e.g. a city, state or country) to follow. The government also enforces the laws to keep the citizens safe. (1 slide)
4. Explain that there are different forms of governments. (1 slide)
  - a. A *monarchy* is where one individual rules as king or queen. The power then gets passed down in their family. Before the United States of America was formed, King George III of Great Britain ruled the colonies. (1 slide)
  - b. A *democracy* is where the citizens vote to establish laws and make decisions that relate to the whole group. The United States of America today is a democracy. (1 slide)

5. Explain that the United States democracy used some ideas from Ancient Greece and some from Ancient Rome. Review the location of Greece and Rome on the map. (1 slide)
6. Over 2,000 years before the US created a new government, Athens—in ancient Greece—experimented with a democracy. Explain that Athens had a *direct democracy*. In a direct democracy, all citizens vote to make rules that they will then all follow. (1 slide)
7. Rome, however, had a *representative democracy*. In a representative democracy, citizens elect a smaller group of citizens to make the rules that they will then all follow. (1 slide)
8. After reviewing the background information, complete one of the following two activities to help the students better understand the differences between these forms of government.

Option A 20-30 minutes

1. Divide your class into three groups:
  - a. Corinth, Greece. This group is ruled by a *monarch*.
  - b. Athens, Greece. This group has a *direct democracy*.
  - c. Ancient Rome. This group has a *representative democracy*.
2. For Corinth, select 1 student to be a monarch, explaining that this student will make a decision for the whole group.
3. For Athens, explain that because it is a direct democracy every citizen in that group will each have a vote.
4. For Rome, have the students select 3 representatives. Explain that these representatives will vote on behalf of the group.
5. Present a topic to the class (e.g. choosing what game they can play or something else relevant to the students). Each group will then make a decision about the topic using their government structure.
  - a. in the Corinth group, the student selected as monarch makes the decision for his or her group.
  - b. in the Athens group, the students all vote and the majority decides.
  - c. in the Rome group, the representatives can listen to what the group suggests, but ultimately only those three representatives' votes count.
6. Share the results from each group with the students. If the relevant topic you selected can apply to each group individually, have the final decision do so. If it can only apply to the class as a whole, use the final decision from the three groups and let the choice of the majority of the three decide for the entire class.
7. Discuss with students.
8. Conclude with the worksheet for Activity 1.

Option B To run concurrent with other activities

If you want to give the students a better sense of the legislative system and process of rule making in these different governments, try this variation. Inform the students that they will

be participating in three different forms of government to either create a set of rules for the classroom to follow, or to make changes to the already established classroom rules (you decide if this means that they can change some of the rules in place or that they can only add other rules). The entire class will follow the decisions made by each government in the three successive school days (the monarch's rules one day, the representative democracy's another, and the direct democracy's yet another). Because this is a simulation with real consequences, the teacher reserves the right to act as dictator with veto power on inappropriate or unsafe rules while trying to give the students a sense of autonomy throughout the course of the exercise.

1. *Monarchy simulation:* Select a monarch for the class. While the rest of the class is doing another exercise, have the monarch sit separately and draft a set of classroom rules (or changes/additions to existing rules). The student would hand this into the teacher, but the class would not discuss this yet.
2. *Representative democracy simulation:* Then, have the entire class elect 3 or 5 representatives. (You can have them each write 3 or 5 names on a paper, collect the ballots, tally them, and announce the 3 or 5 students with the greatest number of votes.) When asking the students to select representatives, remind the class that they should select students who they think will do a good job, because the class will need to follow the rules they establish for one whole day. The representatives will then sit separately and quietly draft rules/changes while the rest of the classroom completes another activity. Suggest that the students use a majority vote to settle any disagreement or that they collectively vote on each suggestion an individual in the group makes. Collect their drafted rules, but do not discuss yet.
3. *Direct democracy simulation:* Finally, the whole class would work together as a *direct democracy*. Students can raise their hands to propose rules or changes and the teacher would write all proposals on the board. After gathering these suggestions, go through each proposed rule one by one and have students vote to approve the rule or not. Majority wins.
4. Review the decisions that the group made as a whole. Then review what the representative democracy and the monarch decided.
5. Discuss with students their reactions to the exercise.
  - a. As a citizen of this classroom, how did you feel about the monarch making rules for the class to follow?
  - b. How did you feel when you elected representatives to make rules for the class to follow?
  - c. How did you feel when all citizens suggested rules and voted on which ones you would all follow?
6. Conclude with the worksheet for Activity 1 and follow through with letting the rules apply to the class in three subsequent days.



Name: \_\_\_\_\_

Page 1

Date: \_\_\_\_\_

### Activity 1: Democracy in Greece, Rome and the United States

Before the United States of America became a country, it was a **colony** of Great Britain. The colonists had to follow laws made by King George III of Great Britain, but many colonists were frustrated with his laws. The American Colonies declared independence from Great Britain in 1776. The people of the United States wanted a new government. When the founding fathers of the United States—people like James Madison—created the Constitution, they chose to make the new government more like the governments of Ancient Greece and Ancient Rome.

Ancient Greece was made up of different **city-states**. Corinth, Athens and Sparta were three of the city-states. Each city-state had its own government. A **monarchy** is a government in which a king (or queen) rules. Corinth had a monarchy. An **oligarchy** is where a small group rules. Sparta had an oligarchy. Athens, however, had a **direct democracy**. This means that the **citizens** voted to make their own rules. Greece is called the “birthplace of democracy.”<sup>1</sup>

Ancient Rome had a **representative democracy**. In a representative democracy, citizens vote for a smaller group of citizens to make rules for everyone.

The United States Government was set up so that citizens elect a smaller group of citizens to Congress. Congress is made up of the Senate and the House of Representatives. These Senators and Representatives make the laws and rules that everyone follows. In local governments, citizens will sometimes all vote to make a decision. For example, the county might want to build a new recreation center and everyone in the county might vote whether to build it or not.

#### Questions:

1. What kind of government did Athens have?
2. What kind of government did the Ancient Romans have?
3. In what ways is the United States government like Ancient Athens?

---

<sup>1</sup> <http://greece.mrdonn.org/government.html>

4. In what ways in the United States government like Ancient Rome?
  
5. Think about the activity the class did exploring different forms of government. Did you prefer one form of government over another? Why?
  
6. Use the chart below to list at least one advantage and disadvantage to each form of government.

Type of Government	Advantages	Disadvantages
<p><b>Monarchy</b> (like Corinth or Great Britain)</p>		
<p><b>Direct Democracy</b> (like Athens)</p>		
<p><b>Representative Democracy</b> (like Ancient Rome)</p>		



Name: \_\_\_\_\_ Page 1

Date: \_\_\_\_\_

## Activity 2: Classical and Neoclassical Architecture

During the founding of the United States, people like George Washington copied elements of Greek and Roman art and architecture. Ancient Greek and Roman art and architecture are described as **classical**.

George Washington's step-granddaughter, Martha Custis Peter and her husband, Thomas Peter also liked the **classical** style. Over two hundred years ago, they built a house in Georgetown and called it Tudor Place. Tudor Place was built in the **neoclassical**, or "new classical," style.

Look at the diagrams below showing elements of Greek and Roman architecture. Draw each element in the box provided. Then, look at the picture of Tudor Place on the back of the page. What similarities do you see?



**Columns** at the Parthenon in Athens, Greece.

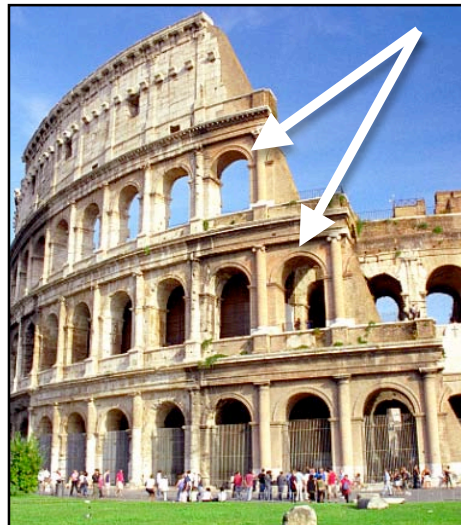

**Arches** at the Colosseum in Rome, Italy



**Dome** atop the Pantheon in Rome, Italy

1. Draw a column:

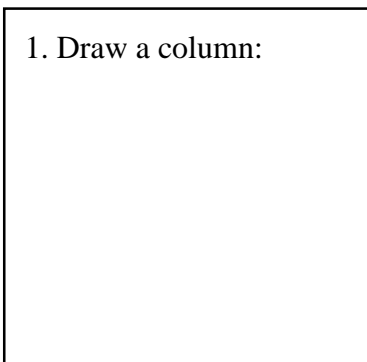

2. Draw an arch:

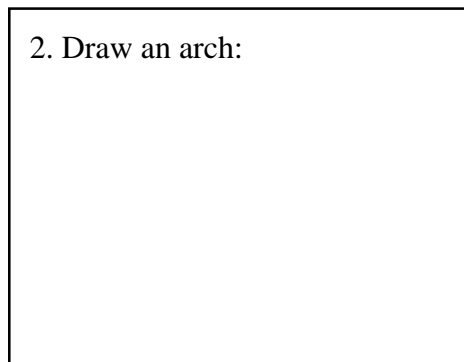

3. Draw a dome:

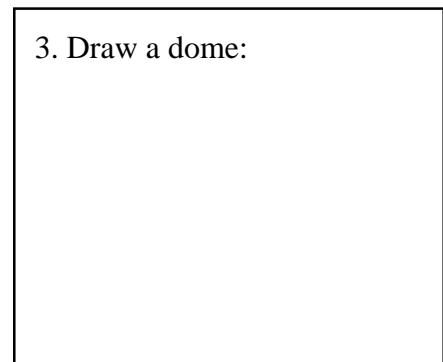

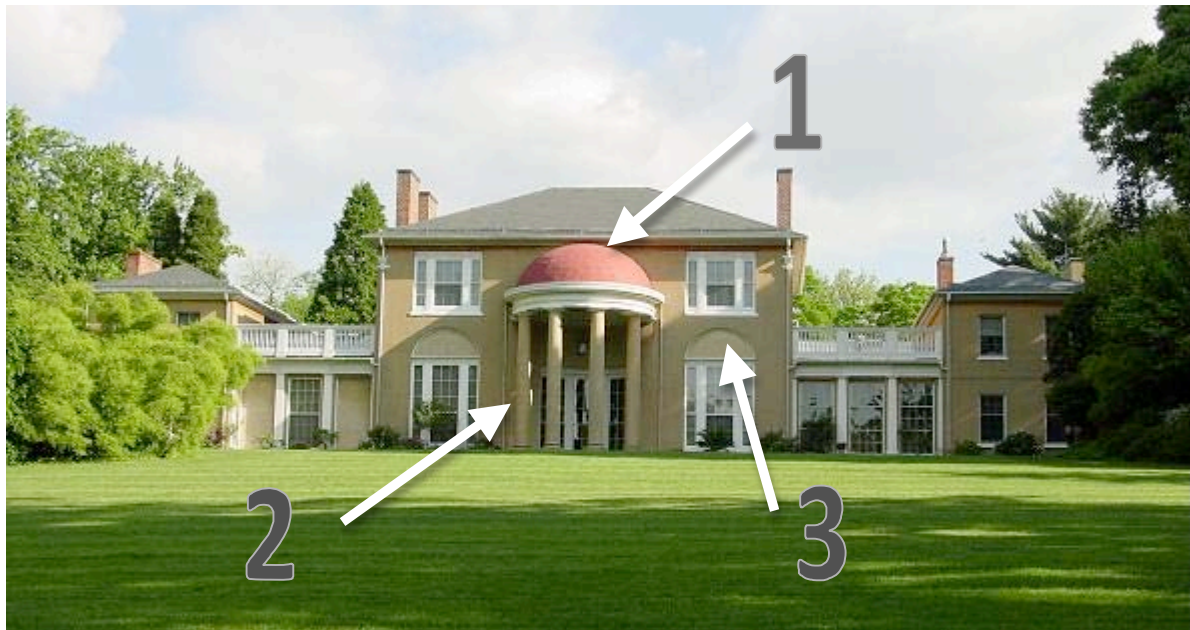

**Directions:** Compare the architecture of Tudor Place in this picture to the architecture on the previous page. Label each architectural element in the space provided.

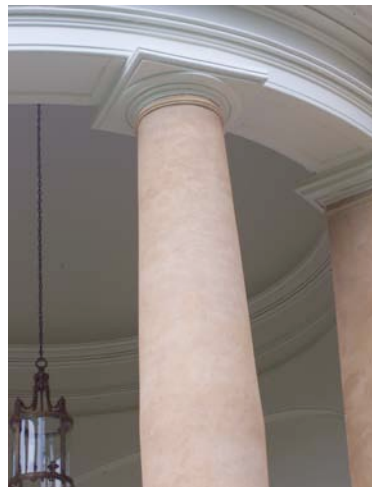

4. \_\_\_\_\_

5. \_\_\_\_\_

6. \_\_\_\_\_

7. Circle the culture or cultures that used arches in their buildings.

Ancient Greece / Ancient Rome / Early 19<sup>th</sup>-Century United States

8. Circle the culture or cultures that used columns in their buildings.

Ancient Greece / Ancient Rome / Early 19<sup>th</sup>-Century United States



## Activity 3: The Love of Gold

### Teacher Information and Lesson Plan

**Rationale:** This lesson and related activity are intended to provide students with an understanding of how gold was important in ancient Greek and Roman art and in the Roman economy. The activity is intended to get students to understand that by flattening gold and applying it as thin sheets or as gold leaf, the ancient Greeks and Romans were able to make the precious material go farther, while still creating beautiful objects.

#### Lesson Materials:

- Optional: Corresponding PowerPoint Presentation

**Lesson overview:** Today we are going to discuss the importance of gold in ancient Greece and Rome and how they used gold in artwork and jewelry. We will also discuss how people in the neo-classical period (New Classical) admired this use of gold and incorporated it in the objects they made and decorated. (1 slide)

1. When Alexander the Great was traveling in the Near East, he seized gold from the people there and gave it to his soldiers who then took it home with them and used it for trade. (2)
2. The entire economy of the Roman Empire was based on gold and silver because they didn't have enough food production or natural resources to trade with other peoples. Gold in Ancient Rome could be seen everywhere, on statues and as jewelry worn by wealthy men and women. See the *Jupiter Bronze Statue* and the *Aphrodite with Sandal* statue for examples of statues that the Romans applied gold to. Jupiter has gold eyes and lips while Aphrodite has gold bracelets. (4 slides)
3. Where does gold come from? It is a mineral that is formed within the earth and brought closer to the surface with moving plates of earth as well as magma in volcanic movement. As bits of metals (like gold and silver) get moved around and brought closer to the surface, other natural elements like wind and running water can help expose these elements on the surface. When some metal appears on the surface, people may create a **mine** to dig for gold and other minerals that may be buried deeper in the ground. (3 slides)
4. In ancient times, there were gold and silver mines in around the Mediterranean Sea, in places like Greece and Macedonia (what is now Turkey), but also in other places on the European continent. When the Roman Empire was most powerful, they controlled all of the mines in their empire. (1 slide)
5. Gold was very valuable then, as it is today. People, like the Romans, wanted to display their wealth for others to see. Let's do an activity to think through how the Romans might have been able to use gold in their artworks to get the greatest effect. (1 slide)

#### Activity Materials:

- A small lump of modeling clay per student (approx 1" to 1 1/2" in diameter)—Yellow color ideal, but anything would work
- A wooden block or other object, larger than the lump of clay (like a 2" or 3" square)
- Rolling pins and other tools for clay (optional)—If offering these tools, try not to draw attention to the rolling pin unless the kids are having trouble figuring out that they can make the gold go farther by flattening it.
- Corresponding worksheet

1. Hand every student a block of wood (or other object) and a smaller lump of clay.
2. Have them imagine that the clay is a nugget of gold that they dug out of the earth and they want to proudly display it. Have them imagine that the block of wood (or other object) is a statue. Tell them that the wood is a boring/cheap material and you'd much rather have a statue—that looks the same—but made of gold. Encourage them to think about how they might give you a statue the size and shape of the wooden block that looks like it is made of gold, because the more gold you can see, the happier you are and the more respect they have as a Roman citizen.
3. The purpose of the activity is to get the kids to figure out themselves that they can make their gold go farther if they flatten it out and cover the block with it. If they seem stumped, ask them if they are looking at the statue, and really love the sight of gold, what is most important: that they see gold on the surface or that they know that the entire statue is made from pure gold?
4. After the kids begin to figure out that they can make the wooden “statue” appear as if it were made from gold by flattening the clay, discuss how the thinner they make the clay (or gold) the more of it they have to cover other objects or turn into jewelry or coins.
5. It may be important to emphasize that gilding is not about fooling anyone, but it is instead a way for people who love the sight of gold to see more of it with the same amount of material than if they had created the objects entirely out of gold. It just makes the really precious material last longer if you make it really thin and cover objects with it.

After the activity is over, continue the lesson (*1 slide*):

1. Although gold is a metal, it is one of the softer metals and can be somewhat easily worked with. To make gold thinner, it can be hammered, and hammered, and hammered etc. into a thinner sheet. As the mallet strikes the gold, the force of the blow from the flat surface of the mallet makes the gold spread outward. Eventually, this makes it flatter and wider. Today, a nugget of gold the size of a sugar lump can be beaten and hammered to make 108 square feet of gold leaf (so that's a little bigger than a 10 ft. by 10 ft. square). The gold sheet ends up being so thin, it is 1/1000 the thickness of a piece of paper and is so delicate that a breath or the touch of a fingertip could damage it beyond repair.<sup>1</sup> [Note: if you have access to internet, show the children this video of a woman taking flattened gold leaf and cutting it to prepare for an artist to use: <http://youtube.com/watch?v=1rF9jyLeoyk>] Today, companies may use a combination of hand and machine labor to flatten gold into thin leaf. (*2 slides*)
2. People have been making thin gold leaf for over 3,300 years and made thicker gold foil before that. The Egyptians were applying gold to objects over 5,400 years ago. They have used different methods of attaching gold to other surfaces—one that used mercury was highly toxic. Pliny the Elder, in his *Natural History* (c. 77 AD), wrote about how people would attach gold foil using an adhesive (sticky substance like glue) made from egg whites.<sup>2</sup> (*1 slide*)
3. Today, people use a similar method, attaching the gold with an adhesive to surfaces like wood picture frames. For an example, look at *Gilt Mirror TP*, a gilded mirror frame in a bedroom at Tudor Place. When you go to Tudor Place, you will get to gild an object by using glue and very, very thin gold leaf. (*1 slide*)

<sup>1</sup> Jeffrey St. John, *Noble Metals* (Alexandria, VA: Time Life Books, 1984), 22.

<sup>2</sup> Ibid; and Andrew Oddy, “Gilding Through the Ages,” *Gold Bulletin* 14, n. 2 (1981).

## Optional Mathematic Activity

**Rationale:** The purpose of this activity is to explore the concept of volume as it applies to gilding—to understand the mathematical principle behind a gold nugget turning into thin gold leaf. This activity can serve as an introduction to the concept of volume. For advanced students, you can discuss this in mathematical terms, how  $h \times l \times w = V$  and how volume remains constant.

### Materials:

- Counting cubes, 64 per group
  - Pencil and paper
1. Have the students build a rectangular prism that is 4 cubes wide, 4 cubes long and 4 cubes tall. (1 slide)
  2. Have the students record the number of cubes they used, how many were used on each side of the cube: the *length*, the *width* and the *height*. (Should be  $4 \times 4 \times 4$ , totaling 64 cubes). (1)
  3. Then, ask the students to pretend like this cube was a nugget of gold that they were trying to flatten to make a gold sheet out of. Have them use the same number of cubes to build another rectangular prism of any size except that this time it can only be 2 squares (or two layers) tall. After they have built this, have the students record the length, width and height (in number of cubes) for this new form. Ask the students to discuss what they had to do to use the same amount of material (the same number of cubes) but keep it only half as tall. Students should understand that they had to put the squares out to the side of the original 2 layers, making the layers wider. (2 slides)
  4. Have the students once more take off the top layer and distribute the blocks so that they still use all 64 blocks. Have them record the width and length and height of the new formation. (2 slides)
  5. Discuss how when you flatten a gold ingot, like what the students essentially did with their cubes, the material has to go somewhere. The mathematical term for measuring how much space a form takes up (or how much space is inside it) is *Volume*. As you saw with the squares (or what would happen with gold) the volume (how much space it takes up) stays the same. The same amount of material is there. But the *dimensions*, it's height, width and length **did** change. (2 slides)

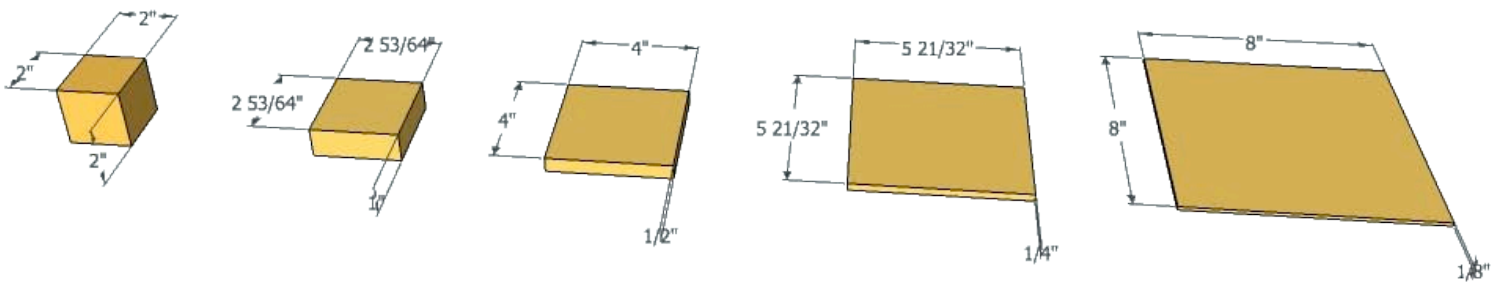

For classes mathematically advanced enough, continue with the following:

Volume

7. We calculate the Volume of a cube by multiplying the length, times the width, times the height. So, in the cube on the left, the height is 2", the width is 2" and the length is 2".

- a. Show a picture of the five cubes illustrated above then write this equation on the board. Length x Width x Height = Volume. So,  $2 \times 2 \times 2 = 8$  cubic inches ( $\text{in}^3$ ).
8. Now, ask the students to calculate the volume of the 3<sup>rd</sup> and 5<sup>th</sup> rectangular prisms. Work through the process with them.
9. For Object 3, what is the length? 4". The width? 4". The height?  $\frac{1}{2}$ ". So,  $4 \times 4 \times \frac{1}{2} = ?$ 
  - a.  $16 \times \frac{1}{2} = ?$
  - b. One half of sixteen equals 8, so the Volume of Object 3 is  $8 \text{ in}^3$ .
10. For Object 5, what is the length? 8". The width? 8". The height?  $\frac{1}{8}$ ". So,  $8 \times 8 \times \frac{1}{8} = ?$ 
  - a.  $64 \times \frac{1}{8} = ?$
  - b. One eighth of sixty-four equals 8, so the Volume of Object 5 is  $8 \text{ in}^3$
11. What was the volume for Object 1?  $8 \text{ in}^3$ . What about Object 3?  $8 \text{ in}^3$ . Object 5?  $8 \text{ in}^3$ . What do you think the volume of Object 2 and Object 4 are?  $8 \text{ in}^3$ . Why is the volume all the same even though they look so different? This happens because you haven't changed the amount of material, even though the dimensions changed. Thus, the Volume remains constant—or, it stays the same.

#### Surface Area

12. The purpose for flattening gold into gold leaf is that you can use less material but achieve the same effect. In the clay activity, we saw how flattening the clay (pretending to be gold) allowed us to cover a shape that was larger than our clay (gold) to begin with. In mathematical terms, what we were doing was increasing the surface area of the clay. Calculating Area is a way to describe how much space there is on a surface. For example, a gardener might want to know the Area of a particular plot of land to know if it would have enough space to grow a particular crop. When you calculate the area of a 3-dimensional form—or how much space it has on it's surface—you are calculating Surface Area. This can be really helpful, for example, if you want to know if you have enough gold leaf to cover a particular picture frame. But before we explore that, let's see how you calculate surface area.
13. On a flat rectangle, like a garden plot, you need two measurements to determine area: the *length* and the *width*. The Area is the length times the width. So, if you have a garden 4 feet wide and 6 feet long, the Area equals 24 square feet ( $\text{ft}^2$ ).
14. But what if we want to determine the surface area of the first gold cube? We must first figure out the area of the individual faces then add them together. The length and width are both 2", so the area of one face of the cube is  $2 \times 2$ , or  $4 \text{ in}^2$ . How many faces does the cube have? A cube has 6 faces, so we must add 4 together 6 times:
  - a.  $4 + 4 + 4 + 4 + 4 + 4 = 24 \text{ in}^2$  OR  $4 \times 6 = 24 \text{ in}^2$
15. Now, let's measure the area for Object 5. Although  $\frac{1}{8}$ " is much thicker than most gold leaf would be, let's see how much surface area we could cover with the gold at that stage in the flattening process. To do so, we will only measure the area of the top plane. What is the length? 8" What is the Width? 8". So,  $8 \times 8 = 64 \text{ in}^2$ .
16. So, at the first step of the flattening process, the 2-inch cube had  $24 \text{ in}^2$  of surface area, but by stage 5, the same amount of gold had  $64 \text{ in}^2$  of usable surface area. This means, that the flattened gold in stage 5 is already big enough to cover an object that was larger than the initial cube in stage 1! Just think how much greater the surface area would be if you flattened it out even more so that it was  $\frac{1}{1000}$  the thickness of a piece of paper.

Use the optional worksheet attached to allow students to practice measuring volume and surface area.

To show the students an example of gilding a portion of a picture frame for restoration, visit the Lunder Conservation Center: <http://americanart.si.edu/lunder/video.cfm?key=4&subkey=1196>.



Name: \_\_\_\_\_  
 Date: \_\_\_\_\_

Surface Area and Volume

Volume =  $length \times width \times height$   
 Area =  $length \times width$   
 Surface area of a rectangular prism = the sum of the Area of all sides

Calculate the **Volume** in cubic inches ( $in^3$ ) for numbers 1-4.  
 Show your work.

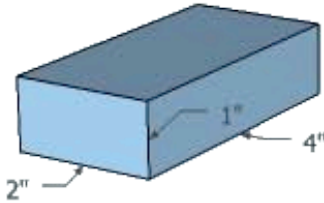

1. Volume = \_\_\_\_\_

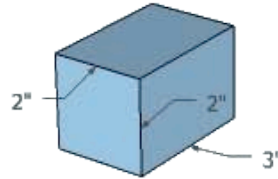

2. Volume = \_\_\_\_\_

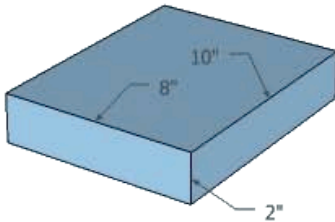

3. Volume = \_\_\_\_\_

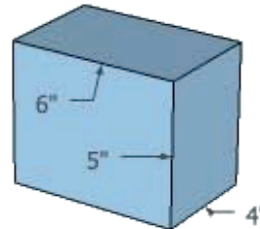

4. Volume = \_\_\_\_\_

Calculate the **Area** in square feet ( $ft^2$ ) for numbers 5-6. Show your work.

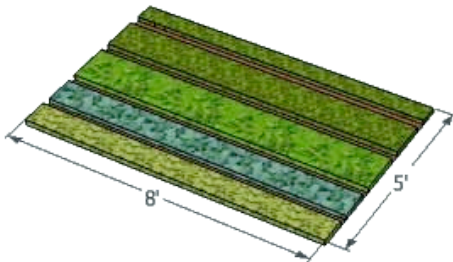

5. Area of a 5 ft. by 8 ft. garden = \_\_\_\_\_

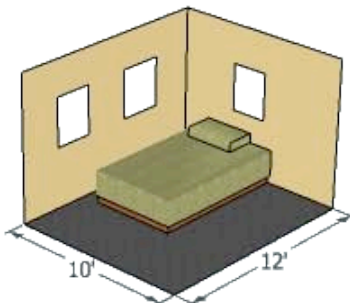

6. Area of a 10 ft. by 12 ft. bedroom = \_\_\_\_\_

Calculate the **Surface Area** in square inches ( $\text{in}^2$ ) for numbers 7-9. Show your work.

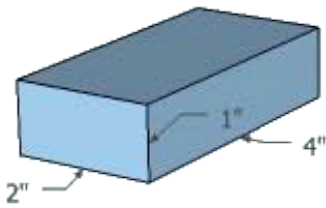

7. Surface Area = \_\_\_\_\_

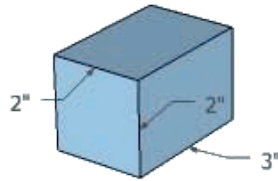

8. Surface Area = \_\_\_\_\_

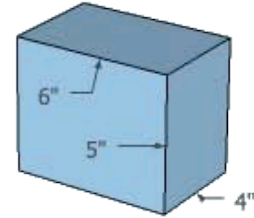

9. Surface Area = \_\_\_\_\_

10. Raul painted a picture that he would like to frame. The painting measures 10 inches by 14 inches. He has two blocks of wood that are each 10 inches long, 2 inches wide and 2 inches tall and two blocks of wood that are each 18 inches long, 2 inches wide and 2 inches tall. The picture below shows how Raul combined these blocks to make a frame for his picture. Raul wants to gild only the front face of his picture frame, but he needs your help to figure out if he has enough gold. Using the measurements and picture below, answer the following questions on a separate sheet of paper and show your work:

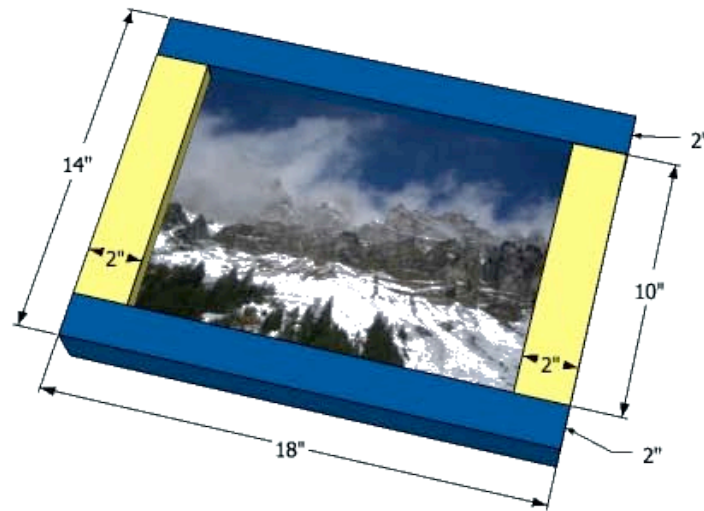

- Calculate the **Area** of the front (top) side of the two shorter blocks combined.
- Calculate the **Area** of the front (top) side of the two longer blocks combined.
- What is the total **Area** of the top side of the frame? (Hint: use your calculations from a. and b. to calculate this).
- Raul has  $120 \text{ in}^2$  of gold leaf. Does he have enough gold leaf to cover the front side of his picture frame?

Bonus: How many square inches of gold leaf would Raul need if he wanted to cover the 4 edges of the picture frame in addition to the front side?



Name: \_\_\_\_\_

Date: \_\_\_\_\_

### Activity 3: From Gold Nuggets to Gold Frames



Gilding is when you apply gold leaf to an object to decorate it. To gild a picture frame like the one shown here from Tudor Place, the gold must first be flattened into very, very thin sheets.

Flattening gold begins with a small lump of gold and a mallet. The lump is beaten to flatten it. Then, the gold sheet is cut into smaller squares, and each square is then put onto a thick goldbeater's skin so that it can be flattened further. Each gold square is approximately 2" x 2" and the goldbeater's skin is approximately 4" x 4". These are layered to make a packet with as many as 400 sheets of gold sandwiched between 400 sheets of goldbeater's skin. This packet gets wrapped in strong paper and is beaten again until the gold gets even thinner, expanding to the edge of the goldbeater's skin. Then, the packet is opened and each layer of gold is cut into four quarters; then it is stacked again between goldbeater's skin. The goldbeater will again wrap the stack with sturdy paper and beat it, repeating this process until the gold is thin enough.

A gilder will use a few of these thin, thin sheets to cover a picture frame like the one in the picture. In order to make the gold leaf stick to the wooden surface, the gilder must first coat the wood with a special **adhesive**. The gilder will then use a clean brush called a gilder's tip to gently lift the gold leaf and place it on the frame. The gilder then uses tools to gently push the gold leaf down onto the surface. Finally, the gilder rubs the gold onto the surface with a tool called a **burnisher**.

The drawings on the back of this page illustrate the process by which gold is made into thin sheets for gilding. Number the drawings in the correct order from flattening a gold nugget to gilding a picture frame.

Using the description from the other side of the page, number these drawings in order.

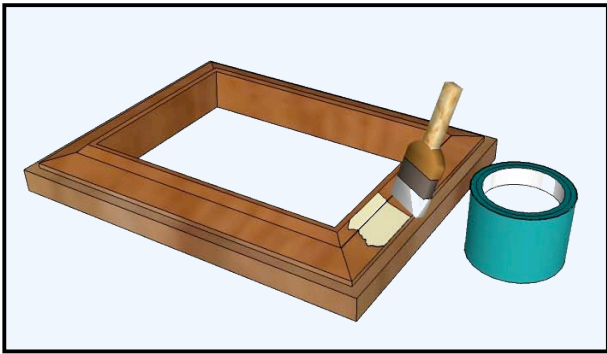

Step \_\_\_ Applying glue to frame

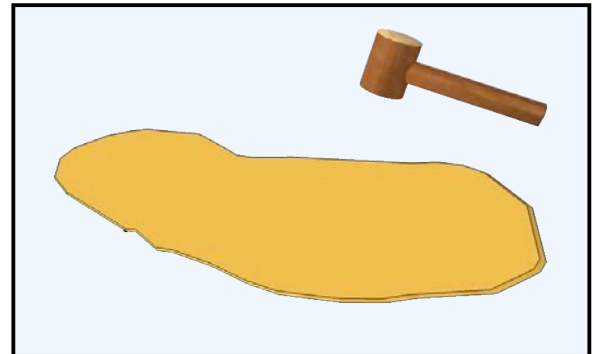

Step \_\_\_ Hammering gold sheet

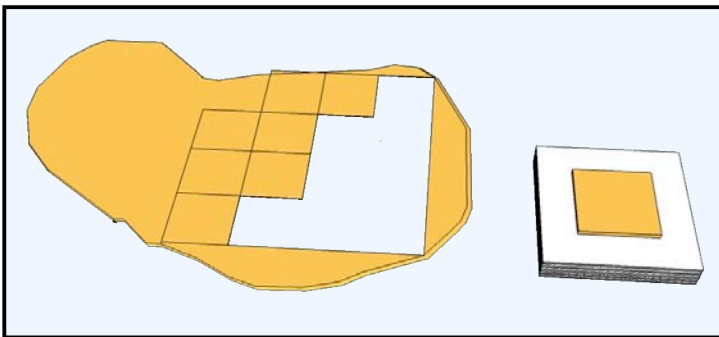

Step \_\_\_ Cutting gold sheet to make a packet

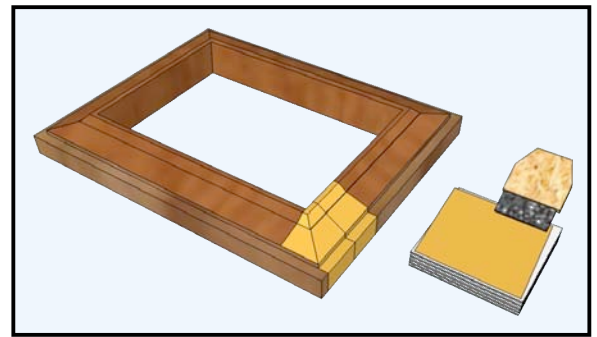

Step \_\_\_ Using gilder's tip to lift gold leaf

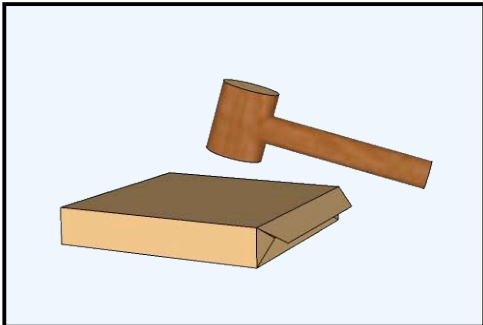

Step \_\_\_ Hammering packet of gold to make thinner



Step \_\_\_ Flattening gold nugget

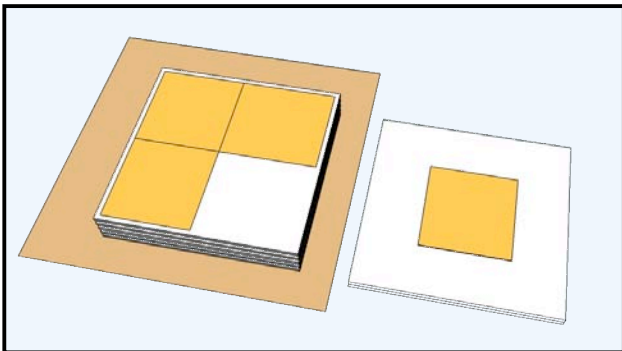

Step \_\_\_ Cutting flattened sheet to flatten again

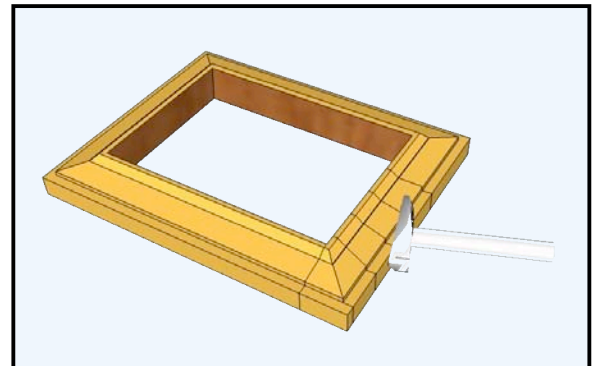

Step \_\_\_ Burnishing gold leaf to make smooth

# Post-Visit Lesson Plans



## Post-Visit Lesson Plan

Listed below are lesson plans for you to use with your class after visiting Tudor Place. All activities correspond to local and national curriculum standards.

### Activity 1: Art Description and Comparison

*Objective:* After completing this activity, students will be able to:

- observe a work of art closely and describe the work of art
- identify ways in which some early 19<sup>th</sup> century artifacts resembled ancient Greek artifacts.

*Answer Key:*

Comparison 1:

- A. Accept all reasonable answers. Note: The relief was carved from marble.
- B. Accept all reasonable answers. Note: The vase was made from porcelain and has paint and gold on it.
- C. Accept all reasonable answers. Suggestions for similarities: both have three women; the woman on the right is sitting in both and holds a musical instrument; the women are both dressed in flowing fabric. Suggestions for differences: the woman in the middle on the vase has her arms up; the woman on the left on the vase is painted with a flowing scarf; the woman on the right is facing a different way, sitting on a different seat etc.; their clothing looks more like a dress while the Greek women seem to be wrapped in fabric; the materials for these artworks are different; one was carved, the other painted.

Comparison 2

- A. Accept all reasonable answers. Note: Students should observe the way the legs curve outward in the back.
- B. Accept all reasonable answers. Suggestions: note the carving of a woman under each arm rest, the circular shapes on the fabric, the way the back legs curl out and the headrest curls back and down.
- C. Accept all reasonable answers. Suggestions:
  - a. Both chairs have back legs that curl outward.
  - b. The Tudor Place chair is made from wood but we don't know what the chair painted on the vase was made from.
  - c. It is hard to see, but the chair in the painting does not have a single, solid back, but the chair from Tudor Place does.
  - d. The chair from Tudor Place has fabric on it.
  - e. The chair on the vase does not have arms.

### Activity 2: Creative Writing: Myths

*Objective:* This assignment allows students to understand the importance and creation of myths in Greek culture by writing their own myth to explain a phenomenon. After completing this assignment, students will be able to:

- define what a myth is and the history of myths.
- create their own myth.

*Answer Key:* Accept all reasonable work.

### Activity 3: Ancient Greek and Roman Sculpture Game

*Objective:* This activity allows students to explore Greek and Roman art and culture through a kinesthetic activity. After completing this activity, students will be able to:

- identify what is happening in some Greek and Roman artwork
- define aspects of Greek and Roman culture
- describe how the Greeks and Romans used artwork and everyday objects to tell stories.



Name: \_\_\_\_\_

Page 1

Date: \_\_\_\_\_

## Activity 1: Art Description and Comparison



National Archeological Museum, Athens



Tudor Place



### Comparison 1

1. The picture on the left is a relief sculpture of the Three Muses. It was carved in Greece around 350 BC and decorated the base of a statue of the goddess Artemis. In the space below, describe what you see in the picture. Who can you see? What are they doing? What are they wearing? What kind of material do you think this artwork was made from?
2. Look at the object from Tudor Place on the right, with a closer picture of the painting below it. This vase was made around 1810 AD. In the space below, write a few sentences describing this vase. Describe the decoration that you can see. What materials might have been used to make this vase? Why might the owner of Tudor Place have wanted this vase?
3. How do these two scenes compare? How are they different?

Comparison 2



National Archeological Museum, Athens



Tudor Place

- A. The object on the left is a hydria vase from Greece made around 440-430 BC. Describe what you see. Pay close attention to the chair the woman is sitting in. Describe it. Does it look similar or different to the chair you are sitting in? How?
- B. The object on the right is a chair in the drawing room at Tudor Place. It was made in the early 19<sup>th</sup> century after archaeologist had uncovered Greek and Roman artifacts. This chair was made in France. Describe the chair. What decorations can you see in both the wood and the fabric? Does it look similar or different to the chair you are sitting in? How?
- C. How do the chair on the vase and the chair from Tudor Place compare? How are they different?



## Activity 2: Creative Writing: Myths

### Teacher Information

**Rationale:** This lesson and related activity are designed to encourage students to creatively approach the Ancient Greek culture by writing their own myth. Students will read the story of Demeter and Persephone, learn about some of the Greek Gods, and then write their own myth explaining a phenomenon they encounter in their own lives. Additionally, students can dramatize their own myth, practicing directing fellow students in a brief play and acting in other students' plays.

### Materials:

- Handout with Greek myth
  - Corresponding worksheet
  - Optional: Corresponding PowerPoint Presentation
1. Remind students of the wax works box from the parlor at Tudor Place, and the screen and paintings they saw in the dining room. Review the way in which these objects tell stories and that these stories come from ancient Greek myths:
    - a. The Wax works panorama tells a story about Hector and his love Andromache. Hector was a hero in the Trojan War and the man who gave George Washington the waxworks equated him with this ancient mythical hero. The story still held power for General Washington off fighting the British.
    - b. The 3-paneled screen from the dining room at Tudor Place tells part of the story of “The Adventures of Telemachus in the Island of Calypso.” This story comes from The Illiad, written by Homer. As the story goes, Odysseus has been missing for 20 years and his friend Mentor and his son Telemachus hear that the nymph Calypso imprisoned Odysseus and they set out to look for him. Odysseus had been imprisoned there for 7 years, but the gods forced Calypso to let her go. The screen shows some of the adventures of Telemachus when he gets shipwrecked on Calypso’s Island.
  2. The Greeks also told stories about their many gods. Sometimes these stories explained natural occurrences (like why the sun rises each day, why we have lightening or why the seasons change). Explain that the ancient Greeks used these stories to explain their world the way that we use the information that we learn from scientific studies to explain our world.
  3. Introduce some of the Greek gods to the students. Explain when the Romans learned about the Greek gods, they decided to add them to their belief system,

but changed their names. (For simplicity's sake, only the Greek names are used here).

4. Tell the students the myth of Demeter and Persephone as an example (or let them read it on the handout included).
5. Using the corresponding worksheet, have the students write their own myth. They can explain some kind of natural phenomenon in a creative way (why the sky is blue, why camels have humps, etc.). Encourage them to use some of the Greek gods, or even invent their own for the story.

### **Optional Activity: Dramatic Interpretation**

1. Have the students translate their story into a play. Review the conventions for writing a script.
  - a. Characters names should be listed at the beginning of the script—any costumes and props required should also be listed in the beginning of the script.
  - b. When writing dialogue, the name of the character speaking should be written in all capital letters and any stage directions should be written in parenthesis (or *italics*).
  - c. Students can divide their story into different scenes if this is helpful. For example, in staging the story of Persephone and Demeter, Scene 1 could take place in the field while Persephone gathers flowers and Hades approaches and kidnaps her. Scene 2 would then take place in Hades—or simultaneously show Demeter on earth and Persephone in Hades. Scene 3 could happen on Mt. Olympus where Zeus sends Hermes to make a deal with Hades; scene 4 would be negotiations; scene 5 would show how the seasons change when Persephone returns to and leaves her mother.
2. Divide the students into 3 groups. Together, they should plan a production of each of their myths, all as separate acts of one play to be performed for the whole class. The student who wrote each myth should cast and direct their act, taking care that each student in the group should perform in at least one of the acts, or more, depending on the number of characters total.
3. Students should gather costume and prop materials as necessary from home and/or the classroom. This can be as polished or rehearsed as desired.



Name: \_\_\_\_\_

Date: \_\_\_\_\_

### Activity 5: Creative Writing: Myths

At Tudor Place, you saw some objects with paintings of Greek and Roman stories, or **myths**. Myths are stories that people create to help explain why things happen the way they do, or even why the world was created. Different cultures have different myths.

The Greeks had not made the kind of scientific discoveries that we now know about weather. Instead, they believed that different gods affected what happened on earth. For example, the god Zeus was responsible for weather events, like lightning. They told stories to help answer questions they had, like why the sun moves across the sky every day or why the seasons change.

Pretend you are an ancient Greek citizen. Write a creative myth explaining why something happens. Maybe you want to invent an explanation for why the sky is blue or what makes fog. Or perhaps you want to explain why platypuses or armadillos look the way they do, or anything else you might want to write a myth to try to explain. Read the myth about Persephone and Demeter for an example.

When you are writing, you might want to include some of the gods that the ancient Greeks believed in. Below is a list of some of the Greek gods.

- **Zeus** was the most powerful of the gods. He was the god of lightening and was married to Hera.
- **Hera** was married to Zeus and was the Queen of the gods. Hera was the goddess of marriage, children, and the home.
- **Poseidon** was the god of the sea.
- **Hades** was the lord of the underworld and thus the god of death and the dead. **Cerberus**, a three-headed dog, guarded the entrance to the underworld.
- **Ares** was the god of war.
- **Hermes** was very fast and served as the messenger of the gods.
- **Apollo**, son of Zeus and brother to Artemis, was the sun god, making it rise each day. He is also associated with music, poetry, archery and medicine.
- **Artemis** was the goddess of the hunt and sister to Apollo.
- **Athena** was the goddess of wisdom, handicrafts and warfare.
- **Demeter** was the goddess of the harvest; Persephone was her daughter.
- **Aphrodite** was the goddess of love and Eros (called Cupid by the Romans) was her son.
- **Hephaestus** was the god of fire.



## Demeter and Persephone<sup>1</sup>

The gods on Mt. Olympus were a moody lot and the mortals in ancient Greece did whatever they could to keep them happy, offering sacrifices and making temples like the Parthenon.

Demeter, one of Zeus's sisters, was the goddess of the harvest; this means she controlled the crops. If Demeter was unhappy, the crops would die and this would mean no food. Thus, it was important to everyone that Demeter be happy. The thing that made Demeter most happy in the world was spending time with her beautiful daughter, Persephone.

One day, Persephone was out in the fields picking flowers and she caught the attention of Hades, the god of the underworld. He fell completely in love with her and immediately kidnapped her, taking her down to the underworld. When Demeter learned this, she was very, very unhappy.

Persephone was beside herself with grief. She had heard a legend that if you ate anything in the underworld, you would never be able to leave again, so she refused to eat and hoped each day that she would be rescued. After a week, she was so hungry that she gave up and ate six pomegranate seeds.

Back on earth, Zeus began to fear for the crops, knowing that Demeter's grief would cause all the crops to die. If the crops died, there would be no food for the mortals and then they would die as well and no longer offer sacrifices and build pretty temples. To fix the problem, Zeus sent Hermes (the messenger of the gods) down to Hades in the underworld to try to make a deal.

Hermes wanted to return Persephone to earth so that she could live again with her mother. However, he learned that Persephone had eaten six pomegranate seeds in the underworld and he knew it meant she could never leave. But, he was able to compromise with Hades: if Persephone would marry Hades, Hades would allow her to leave the underworld for six months out of the year. Hades, Zeus, and Persephone all agreed. Demeter was not pleased, but she understood and finally agreed as well. Thus, when Persephone returns to earth in the spring, the happy Demeter makes the flowers bloom and the crops grow. But, when Persephone leaves her and returns to be Queen of the underworld in the fall, the sad and lonely Demeter cries and lets all the crops die until her daughter returns the next spring.



---

<sup>1</sup> Adapted from <http://greece.mrdonn.org/greekgods/demeter>



## Activity 3: Ancient Greek and Roman Painting and Sculpture Game

### Teacher Information

**Rationale:** The purpose of this activity is to have students explore Greek and Roman art and culture through a kinesthetic activity. By closely looking at Greek and Roman sculpture or paintings and physically replicating the pose or scene, students will make a personal, physical connection to artwork and peoples of the past. By analyzing works of art in this fun, engaging way, students can begin to investigate how people lived in Ancient Greece and Rome and what was important in those cultures.

### Materials:

- Images of Greek and Roman statues (printed for overhead, printed on cards or displayed via PowerPoint)
- Flashcard size images of the above.
- *Statue Game Information\_for Teacher.pdf*
- *Statue Game Information\_for Students.pdf*

### Activity:

1. Discuss with students the different ways in which we tell stories today and document our history. Think about the elements of a newspaper; there are words and pictures that convey information. Photographs can sometimes tell a story as well as the written words. Ask what other kind of artwork can tell stories or document what happened in the past. (Paintings, sculptures, etc.)
2. Ask if Ancient Greeks and Romans could take photographs. Ask the students how Greeks and Romans told stories and documented history, since they did not have the technology of photography that we have today. Get them to think about what objects we can use today to learn about how Greeks and Romans lived: stone sculptures and relief carvings, bronze statues, metal coins, fresco paintings and painting on terra cotta vases.
3. Show the students a series of artworks, telling stories related to the artwork while using them to discuss daily life in Ancient Greece and other elements of their culture and history. See **Sculpture Game Information** document for artworks and related information.
4. Select volunteers (one for each character in the artworks) and give them each (or each group, if the artwork has multiple characters) a flashcard and related information sheet. Out of view of the other students, these volunteers should look at their cards, and gather together in one part of the room and form a sculpture “gallery.” To do so, they will pose as the figure indicated on their flashcard or be assigned a particular character in a scene with multiple people.

**Note:** Some of these artworks involve positions of fighting; you may want to

be clear with the children upfront that statues do not move. Also, some of the figures are shown in the nude. If the children comment about this, inform them that the Greeks wanted to show the ideal human form in their artwork and this is how they thought they could best achieve that. It was part of their culture.

5. Then, take the rest of the students (if space and behavior permits) through the “gallery,” stopping at each statue or tableau to guess which artwork the students are representing. Have the students then tell the story being portrayed or describe what we can learn about ancient Greek or Roman culture from looking at the object.
6. Then, you can repeat with the other half of the class if you choose.



## Glossary

**Adhesive-** n. A substance used to stick two materials together; like glue.

**Burnisher-** n. A tool with a hard, smooth tip, made from metal or stone that is used to polish and smooth metal. Guilders will use a burnisher with an agate (a stone) tip.

**Citizen-** n. A person who lives in a country, state or commonwealth who has legal rights and responsibilities to the country, state or commonwealth.

**City-state-** n. A city, and its nearby territory, that combine to make a state. Ancient Greece was made up of many city-states like Athens, Sparta and Corinth.

**Classical-** adj. A word to describe ancient Greek or Roman culture or artwork, thought or writing related to ancient Greek or Roman culture.

**Colony-** n. A country or area governed by another country. Often a colony is geographically separate from the governing country. The United States first began as 13 colonies owned and governed by Great Britain.

**Direct democracy-** n. A type of government in which all citizens have an equal vote.

**Monarchy-** n. A type of government ruled by a king or queen.

**Myth-** n. A traditional story told by a culture that may explain its early history or explain a natural or social phenomenon (thing that happens). Often myths will have supernatural beings as characters.

**Neoclassical-** adj. Meaning “new classical.” It describes when culture, artwork or thought returns to Classical art and culture in some way. Women’s dresses in the early 19<sup>th</sup> century that tried to look like ancient Greek garments were neoclassical.

**Oligarchy-** n. A type of government ruled by a small group of people.

**Representative democracy-** n. A type of government in which citizens vote for other people to represent them in government, to make laws for all citizens.



Tudor Place  
Historic House and Garden  
1644 31<sup>st</sup> Street, NW  
Washington, D.C. 20007  
202.965.0400  
[www.tudorplace.org](http://www.tudorplace.org)